

**5-2 ARK 2.5H-A1 Connection end face introduction**

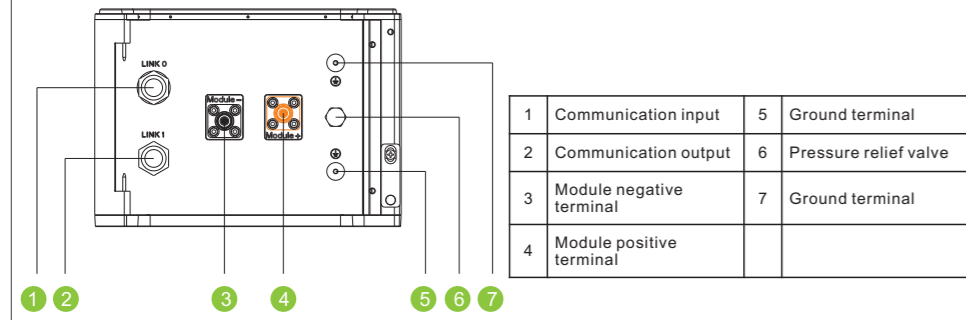

**5-3 Diagram of wiring connection**

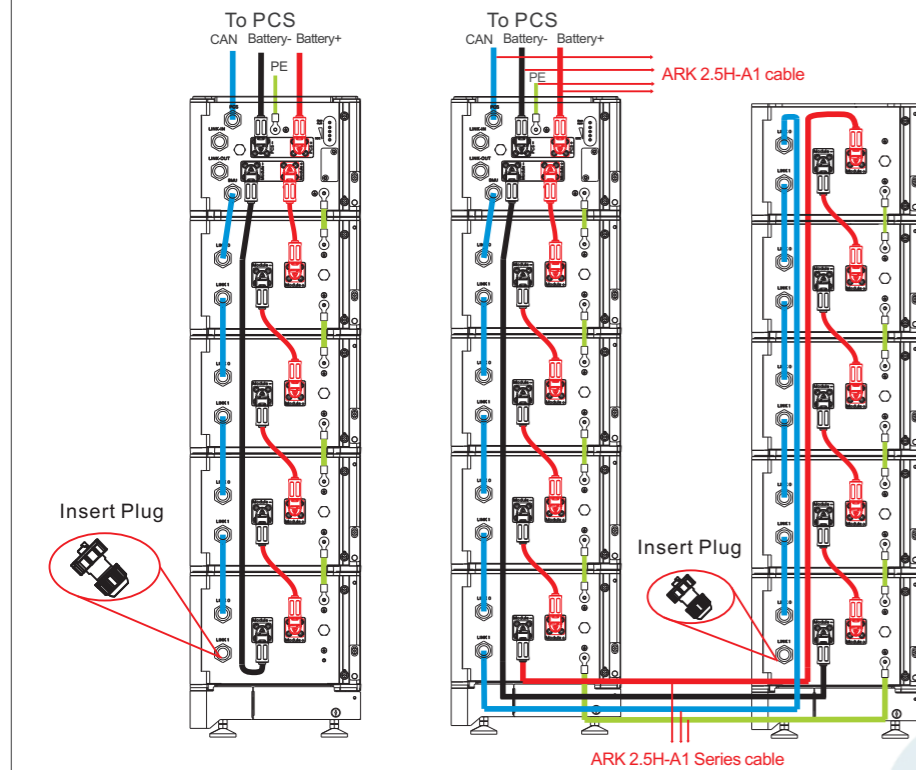

**Note:**  
 1. Before installing the system, ensure that the voltage difference of the battery pack is less than 0.5V;  
 2. For the same system, it is recommended to select the battery with the manufacturing date difference within 3 months, otherwise the system capacity will be limited.  
 3. If there is a switch between PCS and battery, it is recommended to use a circuit breaker with rated voltage greater than 750V and rated current greater than 63A.

**6.Terminal Connection**

**6-1 Power terminal**

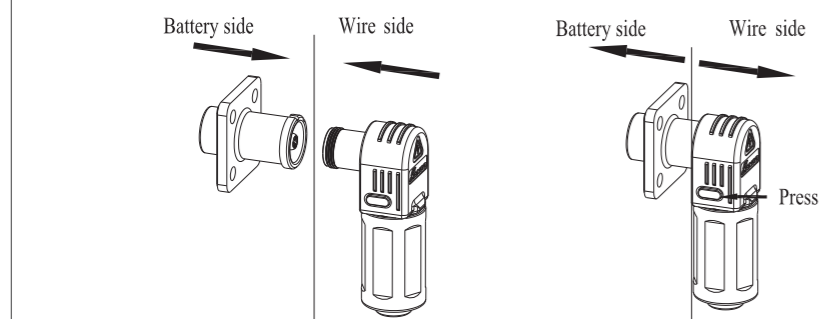

**Note:** Press the position indicated in the figure above before disconnecting the power terminal.

**6-2 Communication terminal**

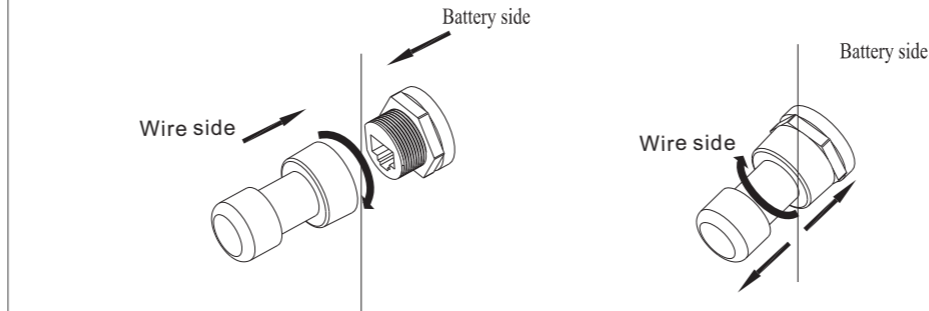

**7.Battery system switch operation**

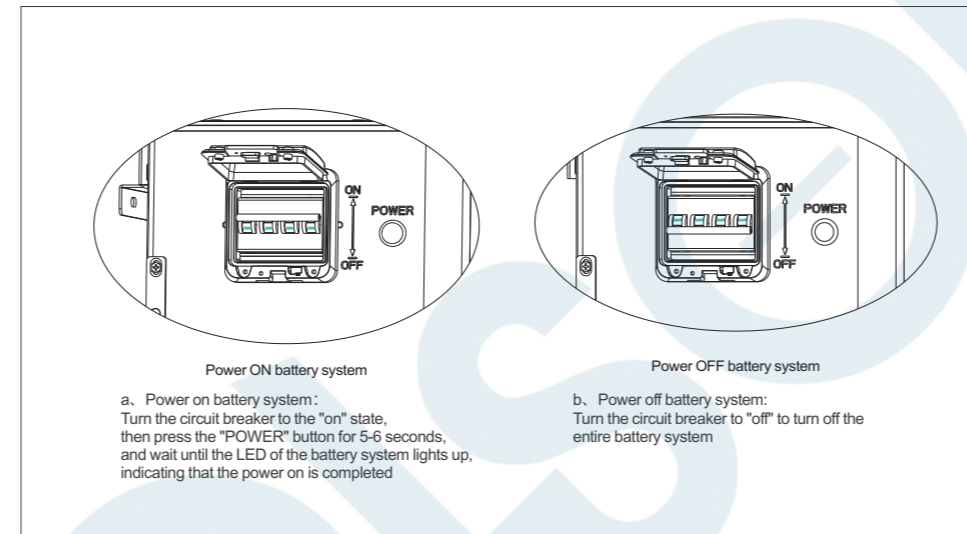

**8.Service and contact**

**Shenzhen Growatt New Energy Co., Ltd**  
 4-13/F, Building A, Sino-German(Europe) Industrial Park,  
 Hangcheng Ave, Bao'an District, Shenzhen, China  
 ☎ 86 0755 2747 1942 ✉ service@ginverter.com  
 W:www.ginverter.com



SOLSOL s.r.o.  
 Králova 298/4, Brno 616 00, Czech Republic  
 podpora@solsol.cz  
 www.solsol.cz

**Installation environment**

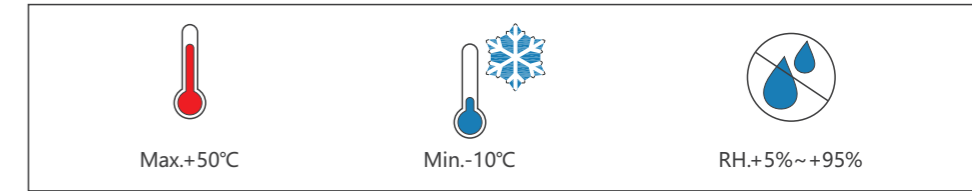

**Installation tools**

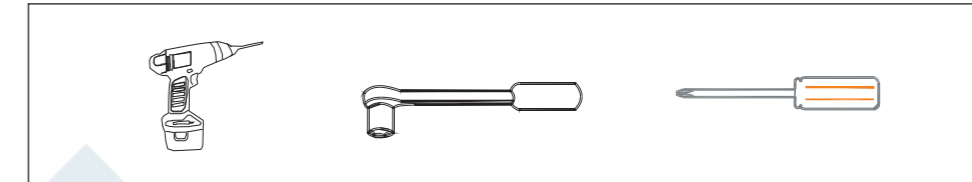

**System size**

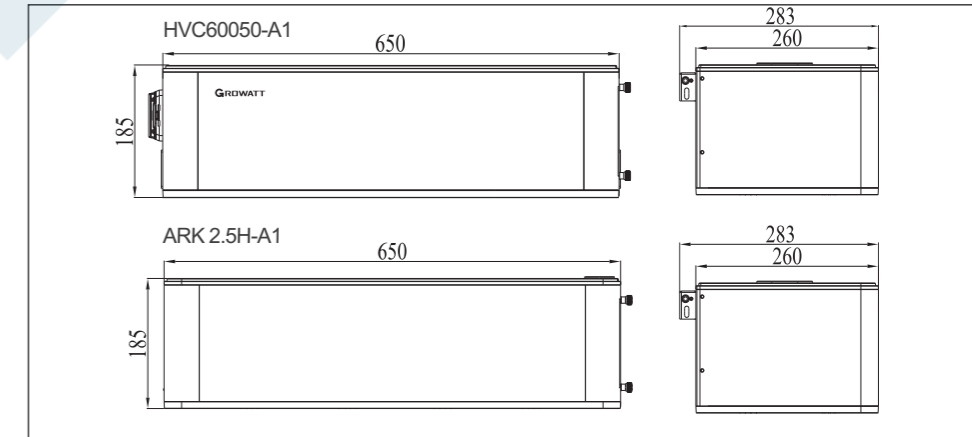

**1.Check**

**1-1 Check HVC60050-A1 List**

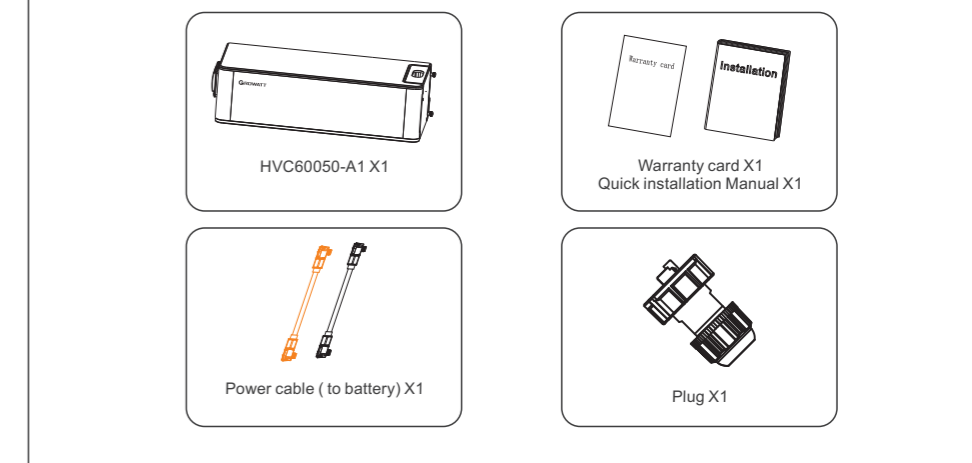

**1-2 Check ARK 2.5H-A1 List**

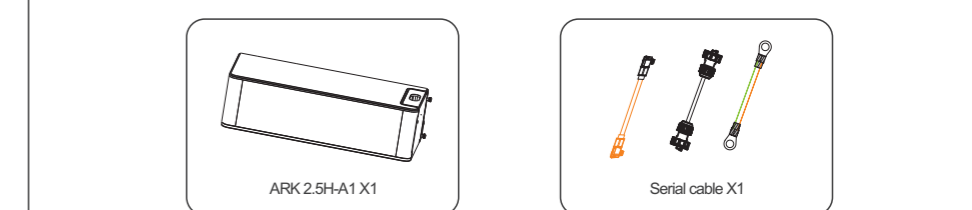

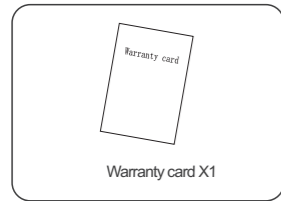

### 1-3 Check accessories

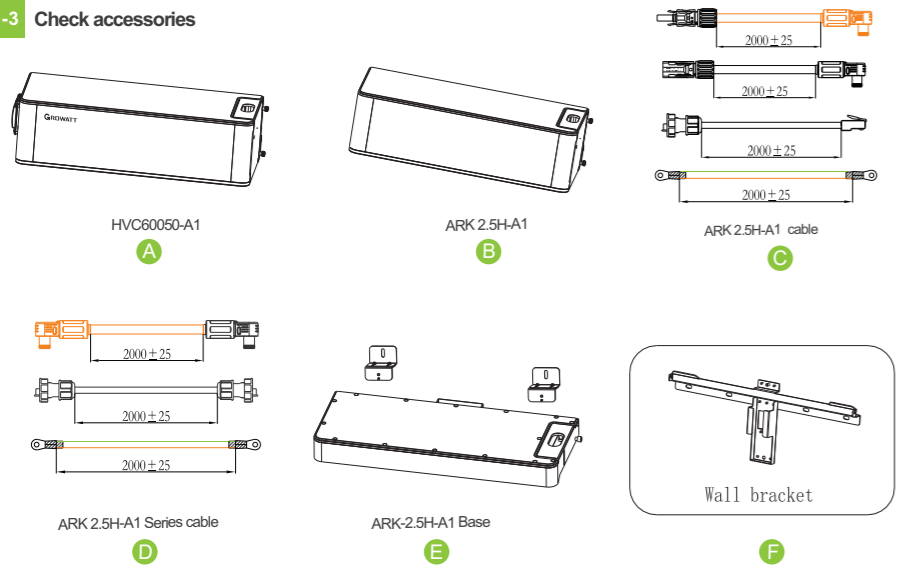

Installation Method	Compound Mode
Standard Wall-Mounted Installation	A+B+C+F*n
Standard floor installation	A+B+C+E
Wall-Mounted Battery system stacked in two line	A+B+C+D+F*n
Floor installation battery system stacked in two line	A+B+C+D+E*2

Note: Wall mounted, one battery with one Wall bracket.

## 2. Floor installation with base

### 2-1 Installation Location Requirements

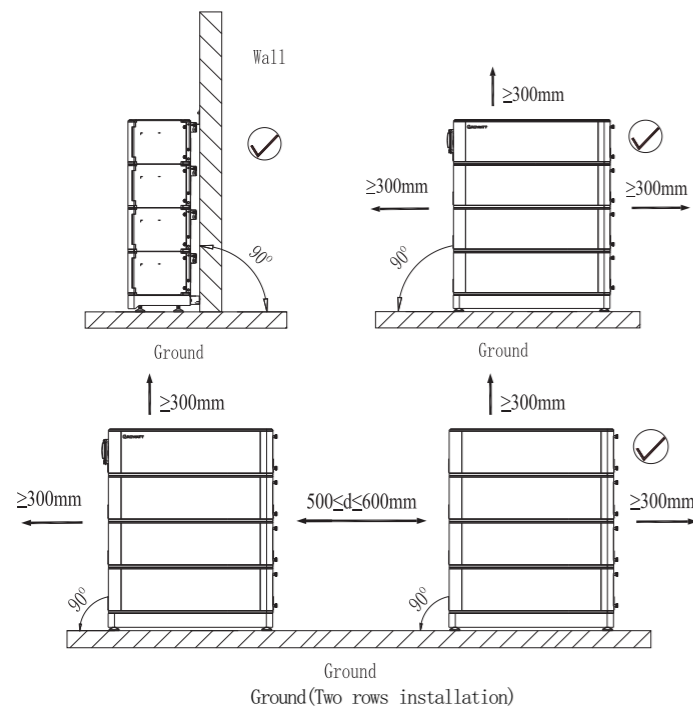

Note: 1. If more than 4 batteries are used, base mounting is recommended.  
2. For floor installation with base, the maximum stack number of the battery is ten. But if the battery number is greater than six, we recommend stacking them in two lines.

## 2-2 Installation Procedure

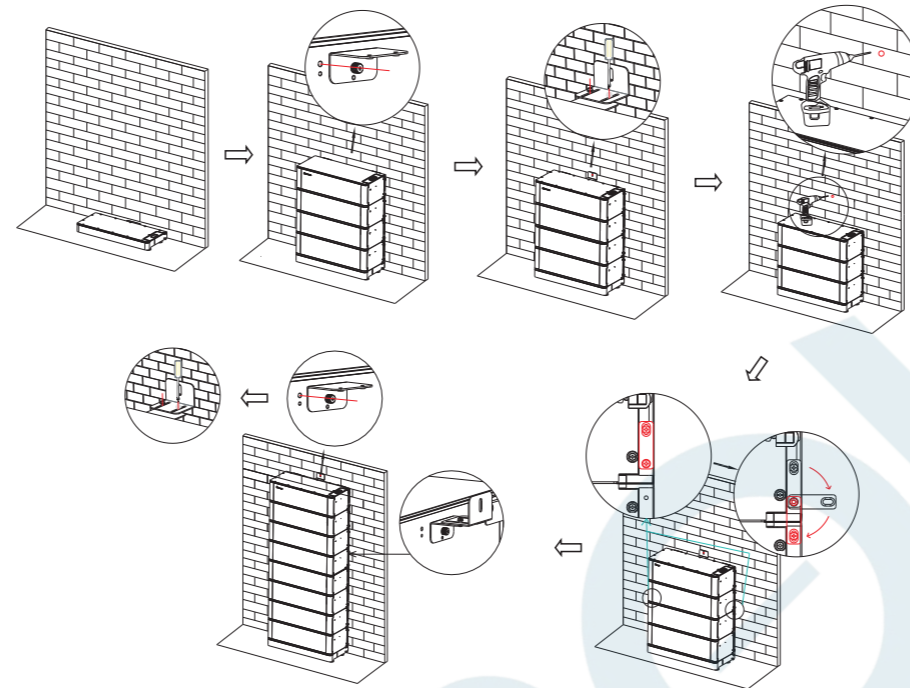

Note: The safety part needs to be installed at the top battery, however, once the number of the battery pack is higher than 7, one more safety part should be installed in the middle battery which is shown the last step.

## 3. Wall-Mounted Installation Process

### 3-1 Installation Location Requirements

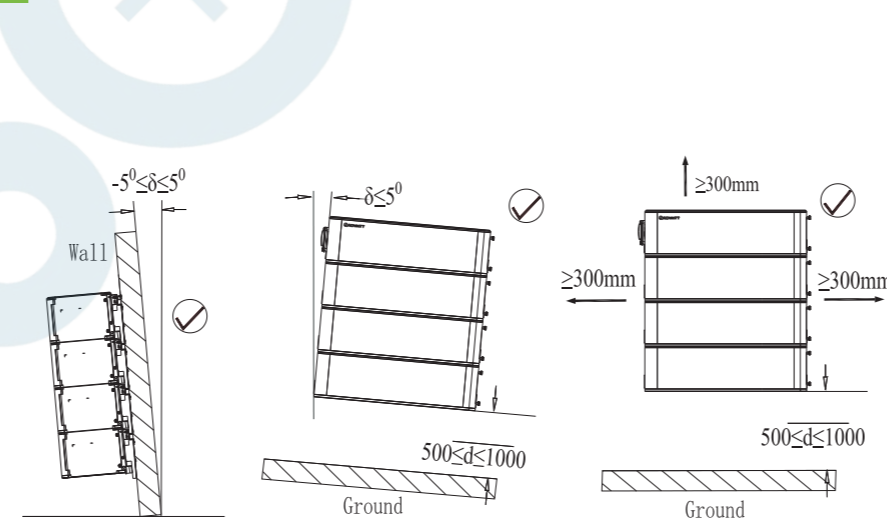

Note: The number of wall-mount installations should not exceed four. Please make sure that the weight capacity of wall should exceed 150kg.

## 3-2 Installation Procedure

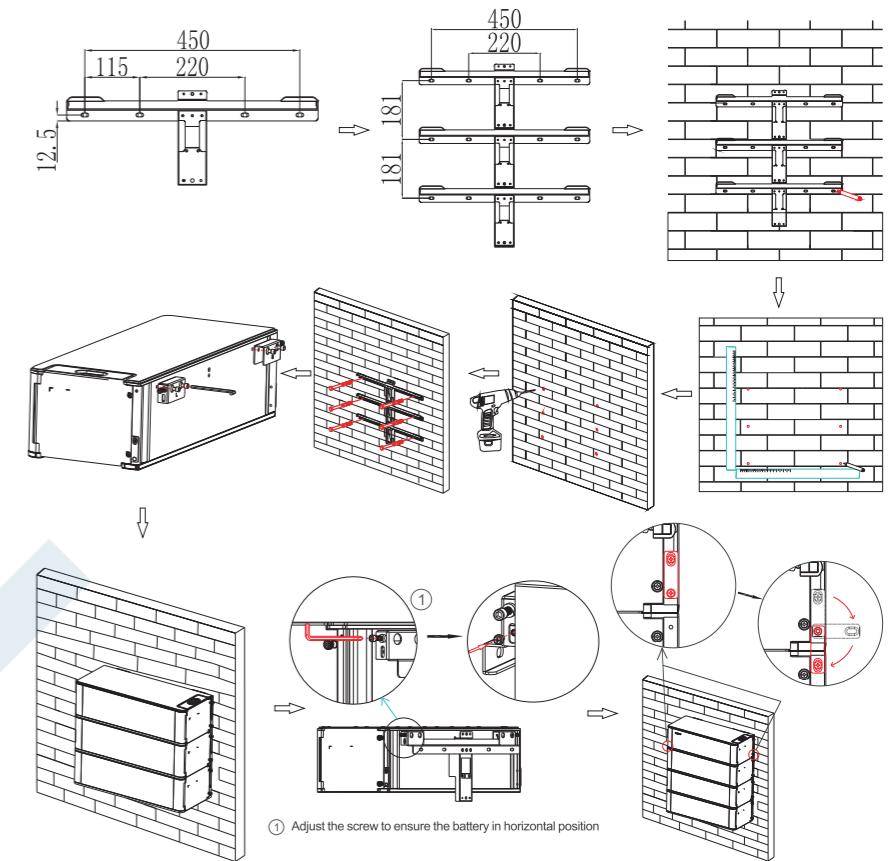

## 4. Install Environment

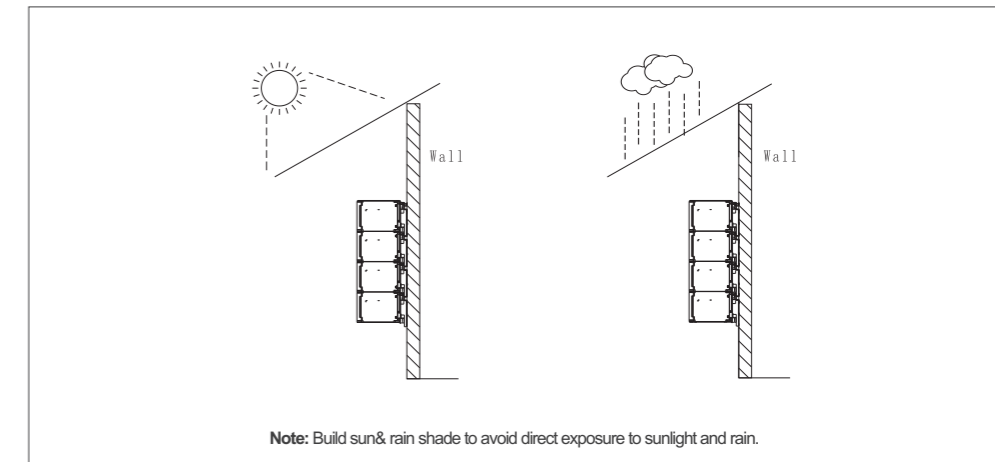

## 5. Wire Connection

### 5-1 HVC 60050-A1 Interface introduction

