

1. Overview

SDM630MCT-MA is a multi-function rail meter, it can accurately measure and display various power parameters in 1P2W/3P3W/3P4W: voltage, current, power, frequency, active power, reactive power, forward power, reverse power, total harmonics, etc. The meter is suitable for real-time power monitoring system, with multi-function, multi-purpose, high stability and long life characteristics. The meter is connected with an external current transformer and is suitable for various high and low voltage power grids. The meter has RS485 communication interface, supports the highest communication rate of 38400bps, can realize remote communication.

2. Technical Parameters

General Specifications	
Rated voltage	3×230/400Vac
Rated frequency	50/60Hz
L-N voltage range	100 ~ 289Vac
L-L voltage range	173 ~ 480Vac
Auxiliary power voltage range	85 ~ 275Vac or 120 ~ 380Vdc
AC withstand voltage	4KV for 1min
Input current range	<40mA
Short-term overcurrent	20*IMAX for 0.5s
Max. Reading	9999999.9kWh/kVArh
Accuracy	
Active power	0.5% of range maximum
Reactive power	1% of range maximum
Environment	
Rated temperature	-25℃~+55℃
Limit temperature	-40℃~+70℃
Relative humidity(average annual)	≤90%
Installation category	CAT III
Degree of pollution	Conform to RoHS
Communication	
Communication	RS485 output for Modbus RTU
Baud rate	9600bps(default)
Pulse	3200imp/kWh
Mechanics	
Mounting dimensions	94.5x72x65mm(LxWxH)
Din rail dimensions	DIN rail 35mm
Protection level	IP51 (indoor)

3. Unpacking

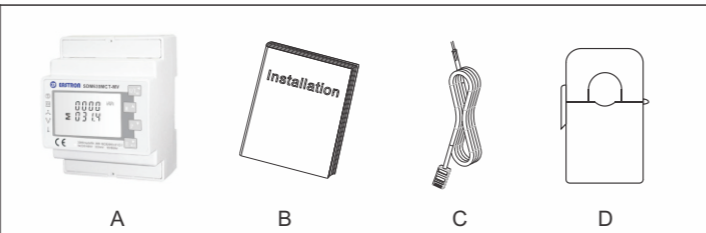

Item	Quantity	Description
A	1	Three-phase meter
B	1	User Manual
C	1	RS485 cable (standard length 15m)
D	3	Current Transformer

4. Dimension(Unit:mm)

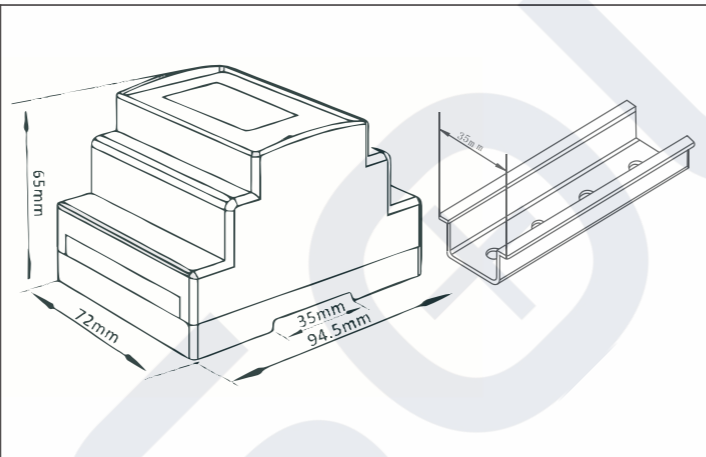

5. Installation

⚠ Note:
We describe Growatt Grid-tied inverter as "PV inverter" and Growatt Hybrid/AC Coupled Inverter as "Hybrid Inverter" as below.

a. Voltage sampling and power supply wiring
Wiring of the L1 voltage sampling line: corresponding to meter Pin 4
Wiring of the L2 voltage sampling line: corresponding to meter Pin 3
Wiring of the L3 voltage sampling line: corresponding to meter Pin 2
Wiring of the N voltage sampling line: corresponding to meter Pin 1

b. Current transformer wiring

- The wiring should be executed according to the picture as shown on left. On the right side is the grid, current flows from P1 to P2.
- Wiring of the L1 CT: S1 corresponding to meter Pin 20, S2 corresponding to meter Pin 19
- Wiring of the L2 CT: S1 corresponding to meter Pin 18, S2 corresponding to meter Pin 17
- Wiring of the L3 CT: S1 corresponding to meter Pin 16, S2 corresponding to meter Pin 15

c. RS485 wiring

•Connect the Rs485 A to Pin 14 and Rs485 B to Pin 13 (There are corresponding line marks on the network cable in the attachment: 485A, 485B; if you use your own network cable, please choose 568B standard network cable, white orange cable is 485B and white blue cable is 485A)

e. When you are installing a PV Inverter, first cut off the RJ45 modular plug, then find two cables and crimp the accessory terminals, finally, put them into the correspond interface of the inverter's 8 Pin signal connector as below.

d. When you are installing a Hybrid Inverter.

f. Plug the 8PIN signal connector to the inverter.

g. The standard RS485 cable length is 15m. If need longer RS485 cable, please use an ethernet coupler to extend and make sure RS485 cable less than 100m (the recommended length is less than 25m).

6. Button Definition And Display

There are four touch buttons on the panel, from top to bottom are "ESC(←)V/A", "↑ (Alt)MD/PH/HZ", "↓ (Shift)P", "ENTER(→)E". There are two types of key operation: long press (Press for more than two seconds) and short press (Pressing time is less than one second).

NO.	Button	Features	Viewable content(short press)
1		Short press: display voltage and current, ← Long press: ESC	Phase voltage, Line voltage, Phase current, Neutral current, Voltage harmonics, Current harmonics
2		Short press: display power factor and frequency, ↑ Long press: Alt	Phase(Total) frequency, Total power factor, Phase(Total) maximum current demand
3		Short press: display power, ↓ Long press: Shift	Phase(Total) active power, Phase(Total) reactive power, Phase(Total) apparent power
4		Short press: display electric energy, → Long press: Enter	Total active electric energy, Total reactive electric energy, Forward active electric energy, Reverse active electric energy, Forward reactive electric energy, Reverse reactive electric energy

Note: This meter and SPH default communication address is 02, the baud rate is 9600, the current ratio is 150A/40mA, if the meter and SPH communication is not on, you can confirm the communication address and baud rate is accurate. Long press: to enter setting menu(default password is 1000), then use and to find the page to be set. If the page flashes, means it can be set through and , otherwise you should press to enter. When you set OK, long press to confirm and then press to exit setting.

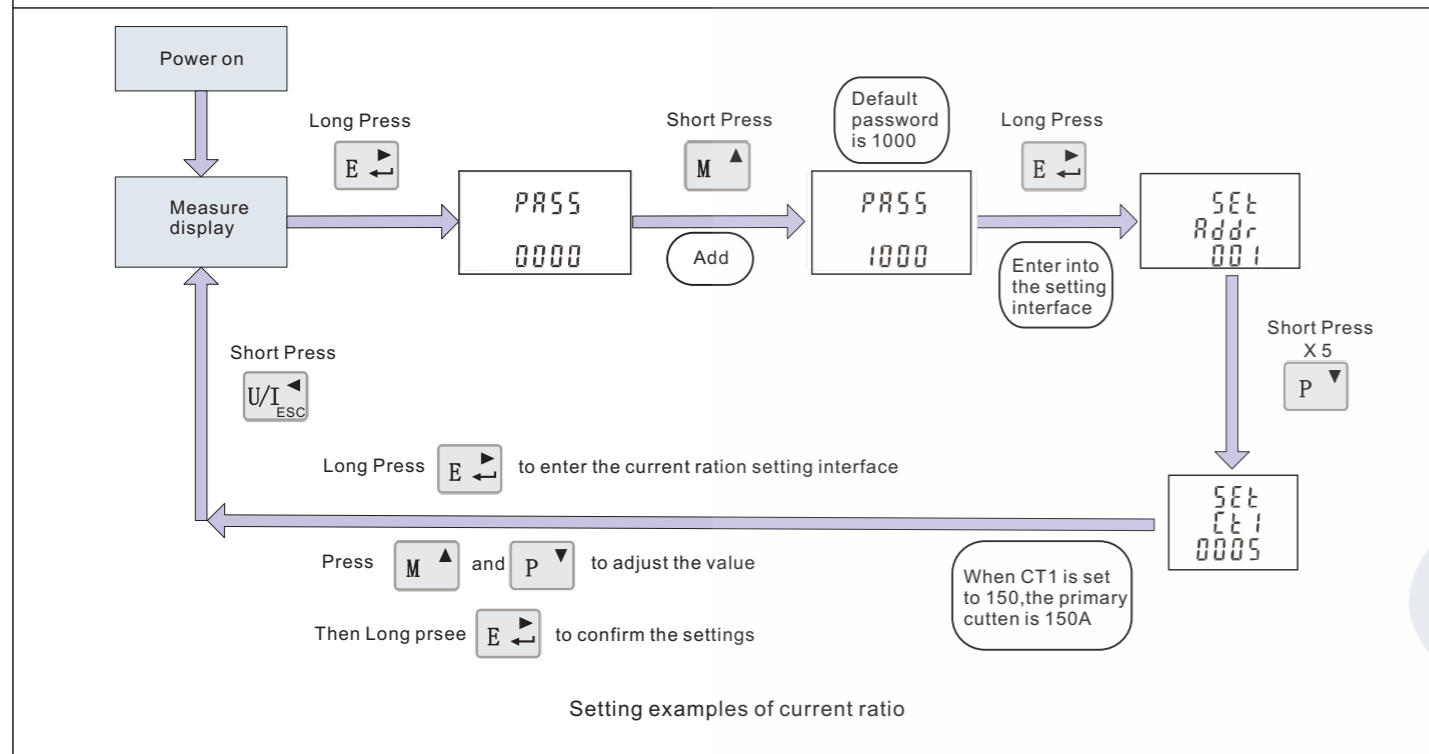

7. Trouble Shooting

Fault phenomenon	Reason analysis	Solution
Big deviation between electric energy measurement and actual value.	<ol style="list-style-type: none"> 1. Wiring error, voltage and current corresponding phase sequence is wrong. 2. If the output line of the current transformers is reversed. 3. The transformer ratio is not set, the meter displays the secondary data. 	<ol style="list-style-type: none"> 1. Refer to the wiring diagram to check the wiring. 2. If the transformer ratio setting is wrong, please set the voltage ratio and current ratio correctly. 3. If the issue still exists, please contact your local supplier.
RS485 communication error (Inverter error 401)	<ol style="list-style-type: none"> 1. RS485 cable is open circuit, short circuit or reversed. 2. The address, baud rate and data parity of the meter do not match the SPH. 	<ol style="list-style-type: none"> 1. If there is a problem with the communication cable, please replace the communication cable. 2. Set the correct address, baud rate, and data bit check digit of the meter by the button. 3. If the issue still exists, please contact your local supplier.

The complete system wiring diagram is as follows, if the meter is not operating normally, you can refer to it to check the wiring.

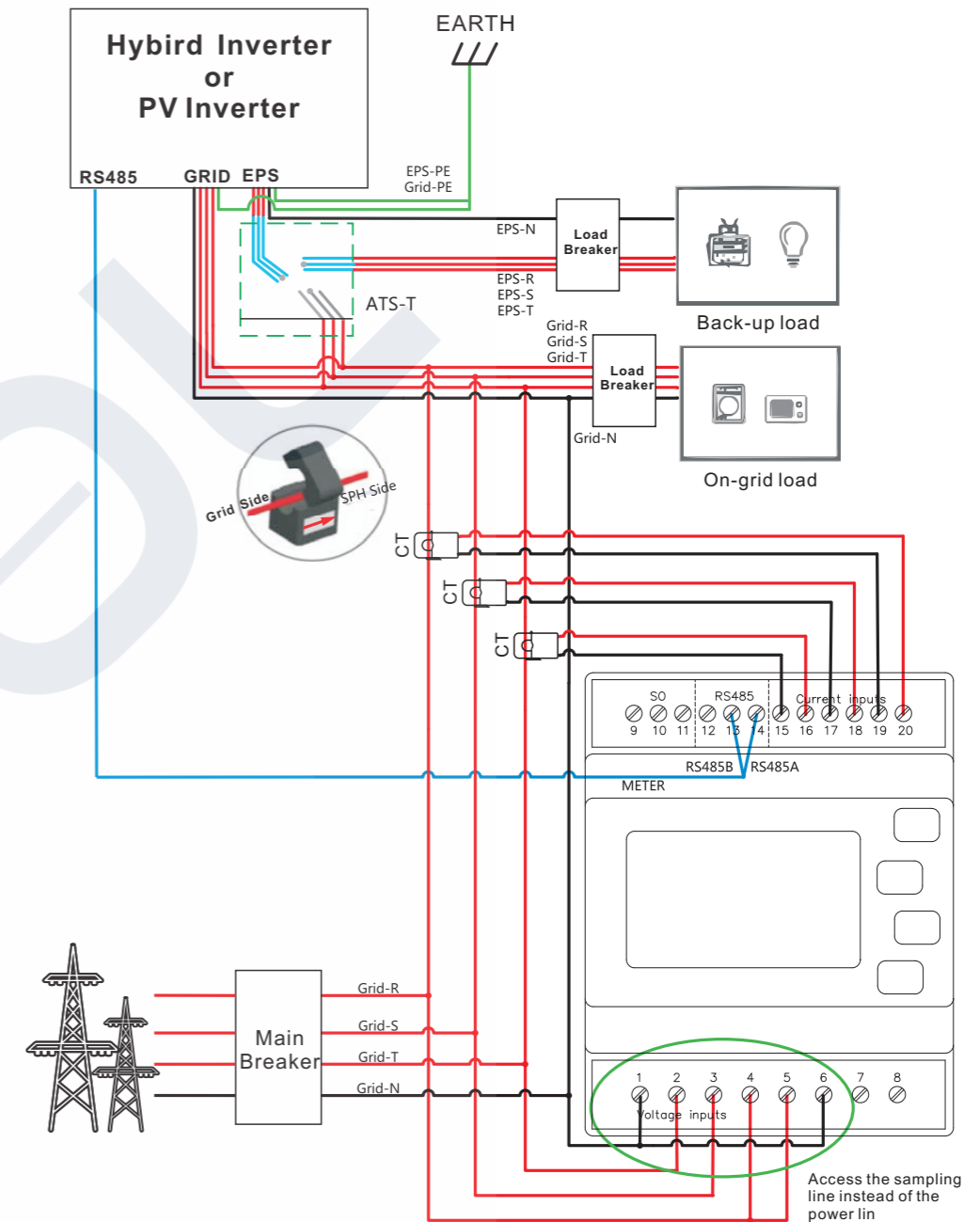

SOLSOL

SOLSOL s.r.o.
 Králova 298/4, Brno 616 00, Czech Republic
 podpora@solsol.cz
 www.solsol.cz



Download Manual



Growatt New Energy

Shenzhen Growatt New Energy Technology CO.,LTD
 No.28 Guangming Road, Shiyan Street, Bao'an District, Shenzhen, P.R.China
 T +86 0755 2747 1942
 E service@ginverter.com
 W www.ginverter.com
 GR-UM-209-A-00