



SDM230-Modbus

Single-phase Meter User Manual

Step1 Overview

The energy-meters "with a blue back-lighted LCD screen for perfect reading" are used to measure single-phase like residential, Utility and Industrial application. The unit measures and displays various important electrical parameters, and provide a communication port for remote reading and monitoring. Bi-directional energy measurement makes the unit a good choice for solar PV energy metering.

Step2 Technical Parameters

General Specifications	
Voltage	230Vac
Voltage range	176~276Vac
Base current(Ib)	10A
Current range	0.5~100A
Power consumption	<2W/10VA
Frequency	50/60Hz(±10%)
AC voltage withstand	4KV for 1 minute
Impulse voltage withstand	6KV-1.2uS waveform
Max. Reading	999999.9kWh
Accuracy	
Voltage	0.5% of range maximum
Current	0.5% of nominal

Frequency	0.2% of mid-frequency
Power factor	1% of Unity
Active power	1% of rangemaximum
Reactive power	2% of range maximum
Active energy	Class 1 IEC62053-21
Reactive energy	Class B EN50470-3
Enviroment	
Operating temperature	-25°C to +55°C
Storage and transportation temperature	-40°C to +70°C
Referencetemperature	23°C±2°C
Relative humidity	0 to 95%, non-condensing
Altitude	up to 2500m
Installation category	CAT III
Degree of pollution	2
Communication	
Communication	RS485 output for Modbus RTU
Baud rate	9600
Mechanics	
Din rail dimensions	36x99x63 (WxHxD) DIN 43880
Mounting	DIN rail 35mm
Sealing	IP51 (indoor)
Material	selfextinguishing UL94V0

Step3 Unpacking

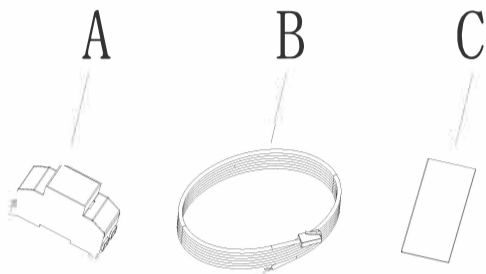

Item	Number	Description
A	1	Single phase meter
B	1	RS485 cable (standard length 5m)
C	1	User Manual

Step4 Dimension (Unit: mm)

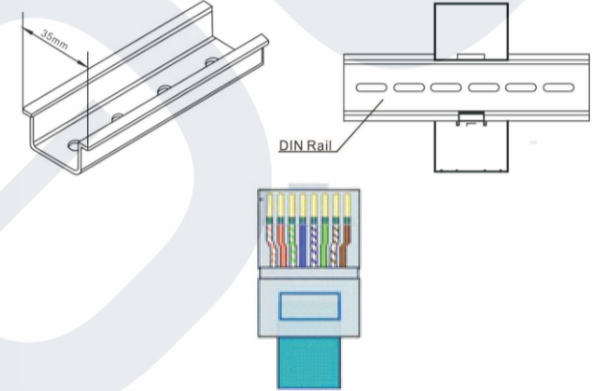
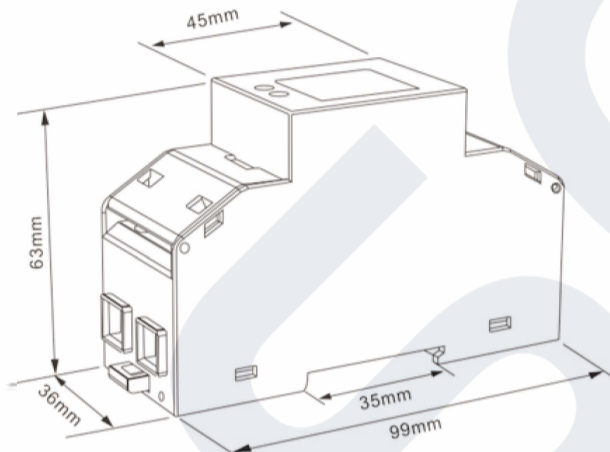

LAN line 1-8 colors as below:

PIN	1	2	3	4
Clour	White orange	Orange	White green	Blue
PIN	5	6	7	8
Clour	White blue	Green	White brown	Brown

Step5 Installation

Wire diagram:

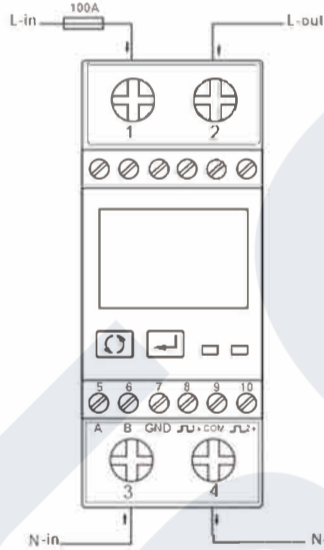

The Ingress Protection rate is IP51 and the pollution degree is PD2, So meter must be install in door. The whole installation chart shows as below:

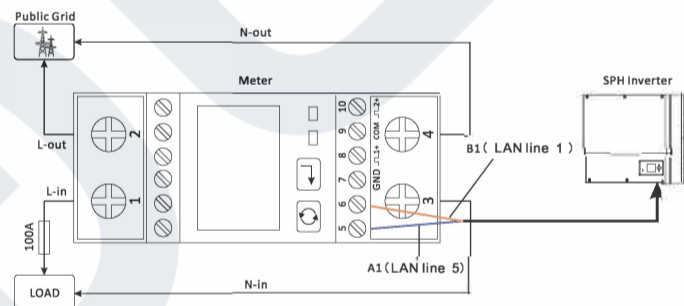

Note: If there is no communication (SPH shows warning 401 or meter communication indicator is don't display), please check the communication LAN line, baud rate, and address.

before screw the cable. Please open the cover of meter:

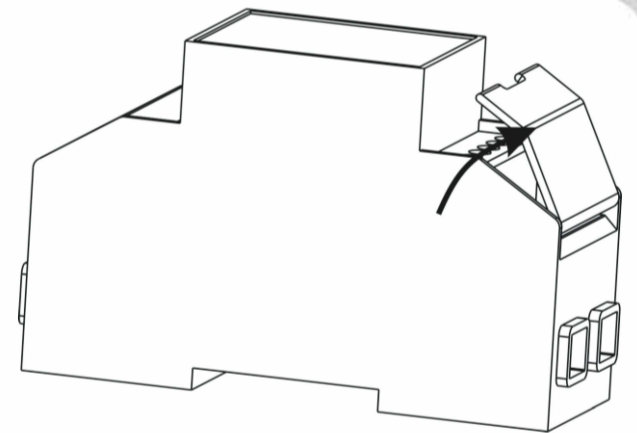

The standard communication cable between meter and inverter is 5m, if it is not enough, Customers can be extended through the network cable.

Note:

1. Be careful the wire of input and output of L/N, if lines are wrong, it may destroy the meter.
2. Be careful the input and output of meter line, if lines are wrong, system will work in a wrong way.

Step6 LCD display

Item	Descriptions
1	7 digits used to display measured values or RTC
2	Total value
4	Import information, Export information
5	Max. Demand for Power or Current
6	Pulse output 1 and Pulse output 2
7	Measurement units
8	PF = power factor Hz = frequency
9	Bar display of Power
10	Communication indicator
11	Time information
12	Low battery warning
13	Lock symbol



When it is powered on, the meter will initialize and do self-checking.



Full screen → software version → Modbus ID → Baud rate → total kWh

Scroll display by Button

After initialization and self-checking program, the meter display the measured values. The default page is total kWh. If the user wants to check other information, he needs to press the scroll button on the front panel.

The display order by scroll button



Total kWh → import kWh → export kWh → resettable kWh → total kVarh → import kVarh → export kVarh → current → W → Var → VA → power factor → frequency → pulse constant → Modbus ID → baud Fate → continuous running time.